

This publication is not intended for distribution in the USA.

SURGICAL TECHNIQUE

PINNACLE[®]
HIP SOLUTIONS

CONTENTS

Introduction	3
Surgical Technique	
Templating and Pre-Operative Planning	4
Acetabular Reaming	6
Acetabular Cup Trialling and Positioning	7
Implanting a PINNACLE® Primary Cup	10
Polyethylene Trial Liners	11
Alternative Trial Bearings	12
Polyethylene Liner Configurations	13
Polyethylene Insert Configurations	14
Implanting the Acetabular Cup with Screw Fixation	15
Implanting the Acetabular with Spikes	17
Polyethylene Liner Insertion and Impaction	18
Polyethylene Liner Extraction	20
Alternative Bearing Liner - Insertion Technique	21
Alternative Bearing Gripper - Insertion Technique	22
Alternative Bearing Liner - Extraction Technique	26
Functional Assessment	27
Tight Exposure and Stability Tips	28
Closure	30
Ordering Information	31



INTRODUCTION

Hip reconstruction has become a successful answer for degenerative hip disease in a more demanding patient population.¹ In addition, hip replacement can provide mobility and pain relief to patients with hip dysplasia or post traumatic arthritis. Experience with total hip arthroplasty has resulted in a more comprehensive understanding of hip anatomy and biomechanics and advances in surgical technique. These advances have allowed the development of more efficient instrumentation and increasingly sophisticated implant design.

The Pinnacle Hip Solutions primary surgical technique has been developed in consultation with an experienced surgeon design team and provides the surgeon with general guidance when implanting the PINNACLE Hip Solutions.



TEMPLATING AND PRE-OPERATIVE PLANNING

The primary goal of total hip arthroplasty is the anatomic reconstruction of the hip joint, resulting in favourable prosthetic joint load and function. Mechanically, the goals are to create a stable articulation with an optimised range of motion, restore biomechanics for muscular efficiency and equalise limb lengths. Meeting these goals begins with a thorough analysis of the hip with comparison to the contralateral side in anteroposterior (A/P) and lateral projections.

The desired magnification for all imaging should be 20 percent, which corresponds to the templates provided for the PINNACLE Hip Solutions (Figure 1a). Magnification markers taped to the patient's leg at the level of the trochanter will assist in determining actual magnification.

For the A/P projection, place both lower limbs in 15° of internal rotation to position the head and neck parallel to the coronal plane. Centre the beam on the symphysis pubis and ensure the proximal femoral shaft is included in the radiograph.

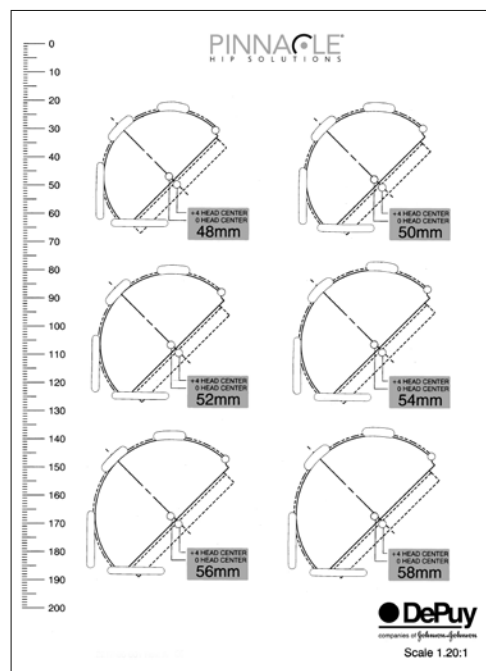

Figure 1a
PINNACLE Hip Solutions Template (Cat No. 2217-00-002)

TEMPLATING AND PRE-OPERATIVE PLANNING

The radiographs should clearly demonstrate the acetabular configuration and the endosteal and periosteal contours of the femoral head, neck and proximal femur (Figure 1b).

Frequently, the affected hip is fixed in external rotation, which leads one to underestimate the amount of offset present. In this situation it may be helpful to template the normal hip. Take into consideration any anatomical anomaly, dysplasia, previous fracture or leg length discrepancy.

The PINNACLE Hip Solutions Templates are oriented at 45° and allow measurement of any hip that can be accommodated by the PINNACLE Hip Solutions Primary components (38 – 66 mm) as well as the PINNACLE Hip Solutions Revision components (54 – 80 mm).

Using the A/P radiograph, position the template 40° – 45° to the inter-teardrop or interischial line so that the inferomedial aspect of the cup abuts the teardrop and the superior-lateral cup is not excessively uncovered (Figure 1c).



Figure 1b
Acetabulum with good lateral coverage

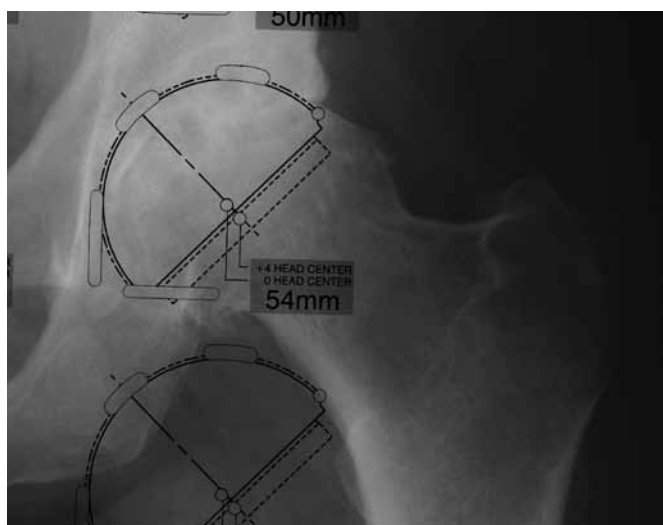

Figure 1c
Properly positioned acetabular template

ACETABULAR REAMING

The goal of acetabular reaming is to restore the centre of the original acetabulum. Initially employ a reamer 6 – 8 mm smaller than the anticipated acetabular component size to deepen the acetabulum to the level determined by pre-operative templating (Figures 2 and 3). Subsequent reaming should proceed in 1 – 2 mm increments. Centre the reamers in the acetabulum until the deepened socket becomes a true hemisphere. Use a curette to free all cysts of fibrous tissue. Pack any defects densely with cancellous bone.

It is important to understand that all PINNACLE Hip Solutions Instrumentation is marked with true dimensions. The reamers, trial cups and actual PINNACLE Acetabular Cups are all 180° (Figure 4).

Under-reaming of the acetabulum is dependent on bone quality and the size of the acetabular component. A 1 mm under-ream is usually sufficient in smaller sockets, while a larger socket may require 1 – 2 mm under-ream. Likewise, soft bone will more readily accommodate a greater press-fit of the acetabular component than sclerotic bone.

In some patients, line-to-line reaming may be sufficient to achieve stability.

Where the acetabulum is reamed often determines where the cup will seat, it is important to ream where the final cup is to be positioned. As such a part of the reamer head will be visible on the superolateral rim when reaming (Figure 3).



Figure 2
Acetabular reaming



Figure 3
Acetabular reaming



Figure 4

ACETABULAR CUP TRIALLING AND POSITIONING

Determining the Abduction Angle

The pre-operative A/P X-ray can help determine the ideal abduction angle (Figure 5) and be helpful in determining how much of the acetabular component should be left uncovered to provide the proper implant abduction angle (Figure 6).

The landmarks for acetabular component positioning are the medial wall of the acetabulum (the radiographic tear drop) and the lateral-superior rim of the acetabulum.

Determining Proper Anteversion

A method for determining proper anteversion is the use of the bony landmark or the transverse acetabular ligament.² Other methods are subject to error through a change in patient position during the procedure. Defining the bony landmarks of the ischium and pubis during exposure greatly facilitates proper acetabular component position.

The plane created by the pubis and the ischium can serve as a guide for proper acetabular cup orientation. The cup should be slightly more anteverted than the pubis/ischial plane. This relationship should remain constant regardless of the depth of reaming (Figures 7 and 8).

Trial cups in 1 mm incremental sizes are available to assess cup fit and orientation. Contingent on the quality of the prepared bone, select the acetabular trial equal to or 1 mm larger in diameter than the final reamer size. The size of the trial cup is as marked on the trial cup (54 mm measures 54 mm). Peripheral rim ridges on the trial cup enhance the stability of the trial cup through trial reduction. Even liner trials fit both even and smaller odd trial cups. For example, a 54 mm polyethylene liner trial fits both the 54 mm and the 53 mm trial cups. Using cup and liner trials in conjunction with the femoral component trials aids in ensuring optimum position of the components.

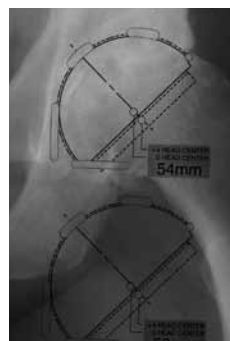

Figure 5
Pre-operative determination of abduction angle

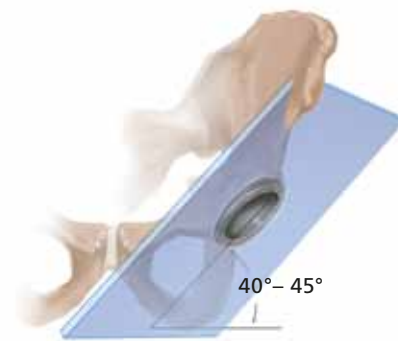

Figure 6
Cup abduction is typically 40°–45°

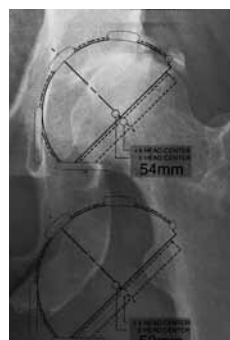

Figure 7
Pre-operative assessment of coverage of the acetabulum

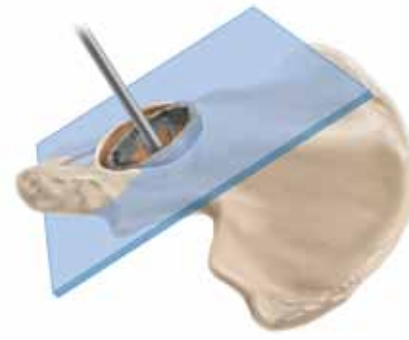

Figure 8
Cup anteversion is typically 15°–20°

CUP POSITIONING

Peer reviewed publications highlight the importance of acetabular component positioning in relation to short and long term outcomes during total hip arthroplasty for all types of bearing materials.³⁻⁸

Cup positioning should be varied to optimise fixation, range of motion and dislocation resistance and minimise the likelihood of subluxation, impingement and edge loading. This may be assessed during pre-operative planning, acetabular preparation and cup trialling. Sub-optimal component positioning may lead to edge loading, dislocation, increased wear, ceramic squeaking and polyethylene fracture.³⁻⁸

The target cup inclination (as measured on radiographs) should be 40-45° taking into account local soft tissue and anatomic landmarks. The target cup anteversion (as measured on radiographs) should be 15-20° taking into account local soft tissue and anatomic landmarks.

An alignment guide is provided to assist with cup positioning; however, cup orientation in the patient depends on patient position. The alignment guide does not allow for variation in patient position with respect to the operating table and it should be noted that patient orientation can vary throughout the procedure.

ACETABULAR CUP TRIALLING AND POSITIONING

(2217-50-041 PINNACLE Straight Cup Impactor/2217-50-044 PINNACLE Version Guide)

An alignment guide is provided to assist with cup positioning. However, cup orientation in the patient depends on patient position. The alignment guide does not allow for variation in patient position with respect to the operating table. It should be noted that patient orientation can vary throughout the procedure.

The PINNACLE alignment guide system may be used to indicate an acceptable level of acetabular inclination and version. Once assembled, the inserter handle should be raised until the vertical bar is perpendicular to the plane of the operating table. With the patient in the lateral decubitus position and the version guide parallel to the floor (Figure 9).

The inserter handle should then be rotated until the horizontal bar is in line with the patient's longitudinal axis (Figure 10).

The extended arm of the version guide follows the long axis of the patient's body, corresponding to the affected hip, to achieve appropriate anteversion.

Confirm complete trial seating by sighting through the holes and cutouts in the acetabular trial cup. The screw hole pattern in the trial cup replicates the PINNACLE Sector Cup Implant screw hole pattern to assist with screw targeting.

Do not use the trial cup to prepare screw holes. Prepare screw holes only through the final implant.

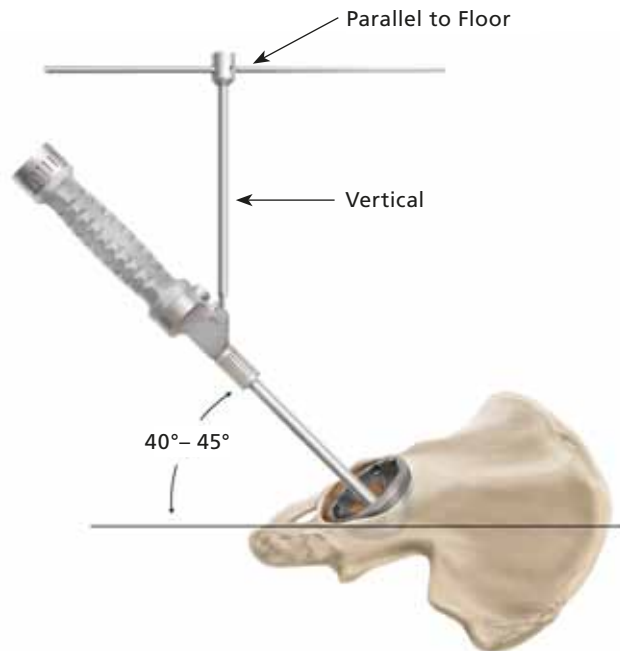

Figure 9
Hold the version guide parallel to the floor and select the abduction angle

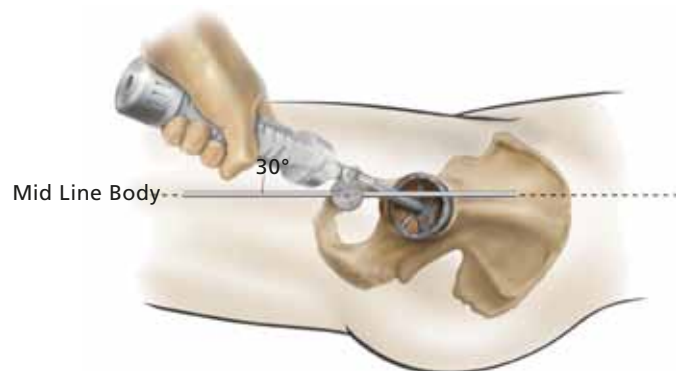

Figure 10
Position the extended arm of the version guide on the long body axis to determine anteversion (30° anteversion angle on the alignment guide relates to 20° of anteversion radiographically)

IMPLANTING A PINNACLE PRIMARY CUP

The natural acetabulum is inclined at an average angle of 50° – 55°. Therefore when a replacement acetabular component is implanted at the correct position, some cup coating will be visible. To achieve the targeted cup position of 40° – 45° inclination and 15° – 20° of anteversion, we recommend that 4 – 6 mm of coating should be left exposed (Figure 13). However, the amount of coating to be left visible is dependant on the angle of the patients acetabulum and the size of the component used.

Cup Insertion

Each PINNACLE Acetabular Cup style is implanted using the same basic surgical technique; however, some cup styles have technique-specific tips that help facilitate implantation. This technique demonstrates the insertion of a PINNACLE 100 Series (no-hole) cup. Before implanting the final prosthesis, take the hip through a full range of motion and stability assessment with all trial components in position. Securely thread the permanent acetabular cup prosthesis onto the acetabular cup positioner (Figure 13). Use the PINNACLE external alignment guide to assist in component orientation.

After confirming alignment, impact the prosthesis into position (Figure 14). Given the nature of a hemispherical acetabular component, rim contact will occur before dome seating occurs. This may require additional impaction to ensure seating. Confirm seating by sighting through the apical hole or, if present, screw holes. An apical hole eliminator may be inserted with a standard hex head screwdriver following cup impaction. Following final component seating, if adjustments to the cup orientation are necessary, thread the impactor handle back into the apical hole to adjust the cup position. **Avoid adjusting the cup position by impacting the taper region and/or cup face with a punch, as this may cause damage to the taper.**

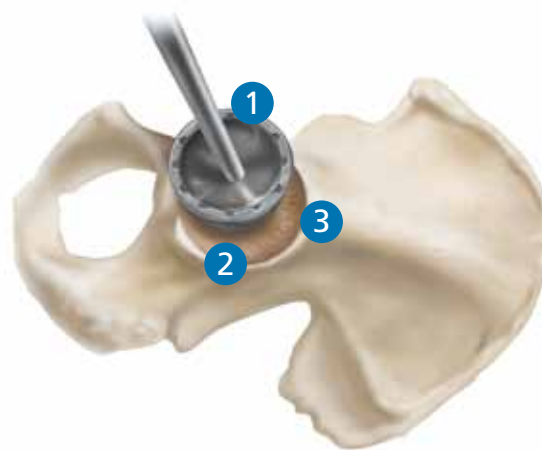

Figure 13
Securely thread the acetabular cup onto the acetabular cup positioner



Figure 14
Confirm acetabular cup alignment

- 1** Anterior notch
Check for psoas tendon impingement with large diameter heads.
- 2** Posterior
Check toe-off impingement.
- 3** Supero-lateral rim
POROCOAT / reamer visible.

POLYETHYLENE TRIAL LINERS

Following positioning and seating of the acetabular cup trial, place the appropriate sized liner trial into the trial cup (Figure 15a). Secure the liner trial to the cup trial through the apical hole screw using a standard hex head screwdriver.

There are various liner configurations for all head sizes ranging from 28 – 48 mm (Figure 15b). With the femoral component trials in position, assess stability and range of motion. Couple the liner trial with the cup trial in the desired position. For liner alternatives other than neutral, there is an orientation reference etch mark on the liner trial and liner implant.



Figure 15a
Trial liners colour guide

Cup and Liner Trial Sizes



Cup Trial Size (mm)	Liner Trial Size (mm)
47, 48	48
49, 50	50
51, 52	52
53, 54	54
55, 56	56
57, 58	58
59, 60	60
61, 62	62
63, 64	64
65, 66	66
67, 68*	68
69, 70*	70
71, 72*	72

Figure 15b

*Appropriate spacer trials to be utilised for head diameters of 28, 32 and 36 mm

ALTERNATIVE BEARING TRIAL LINERS

When implanting an alternative bearing the trial reduction needs to be done with dedicated trial liners (Figure 16).

Please note that alternative bearing trials have a built in offset of +2 mm.

Neutral



28 mm alternative bearing trial liners are YELLOW



32 mm alternative bearing trial liners are PINK



36 mm alternative bearing trial liners are PURPLE



40 mm alternative bearing trial liners are AQUA



44 mm alternative bearing trial liners are RED

Figure 16
Trial liners colour guide

POLYETHYLENE LINER CONFIGURATIONS

In the PINNACLE Hip Solutions, a variety of polyethylene liner designs are available. Each design has specific benefits. It is important for the surgeon to understand the geometry of the various liner alternatives and their impact on joint biomechanics and range of motion (Figure 17).⁹

Range of Motion information in Figure 17 is shown for movements in Abduction to Adduction, see page 14 Table 1 for more information.

Neutral Liner

The neutral liner provides 180° of head coverage. The wide face chamfer is optimised for range of motion. The range of motion measured is 119° with a DePuy Synthes AMT 12/14 Taper Stem and a 28 mm +5 head. The femoral head's centre of rotation is concentric with the outer diameter of the cup.

+4 Neutral Liner

Like the neutral liner, the +4 mm neutral liner provides 180° of head coverage. The wide face chamfer is optimised for range of motion. The range of motion measured is 121° with a DePuy Synthes AMT 12/14 Taper Stem and a 28 mm +5 head. This liner provides a 4 mm lateralisation of the femoral head's centre of rotation. This 4 mm offset both increases soft tissue tensioning and provides 4 mm of increased polyethylene

thickness in the cup's dome region. This lateralised liner can be used as an alternative to a longer neck and may enable the surgeon to avoid using a skirted head. **A +4 mm lateralised liner will result in about 3 mm of leg length and about 3 mm of offset if the cup is inserted at a 45° abduction angle.**

+4 10° Face-Changing Liner

Like the other liners, the +4 10° liner provides 180° of head coverage and the wide chamfer is optimised for range of motion. The range of motion measured is 115° with a DePuy Synthes AMT 12/14 Taper Stem and a 28 mm +5 head. This liner lateralises the femoral head 4 mm and a 10° face change alters inclination/version dependent upon placement of the liner.

Lipped Liner

Range of motion is measured at 106° maximum, with a DePuy Synthes AMT 12/14 Taper Stem and a 28 mm +5 head. The lip on this liner can provide additional stability; however, the impact on range of motion and early impingement must be understood.

Constrained Liners

Constrained liners are available for the PINNACLE cup and are described in brochure 9068-84-052.

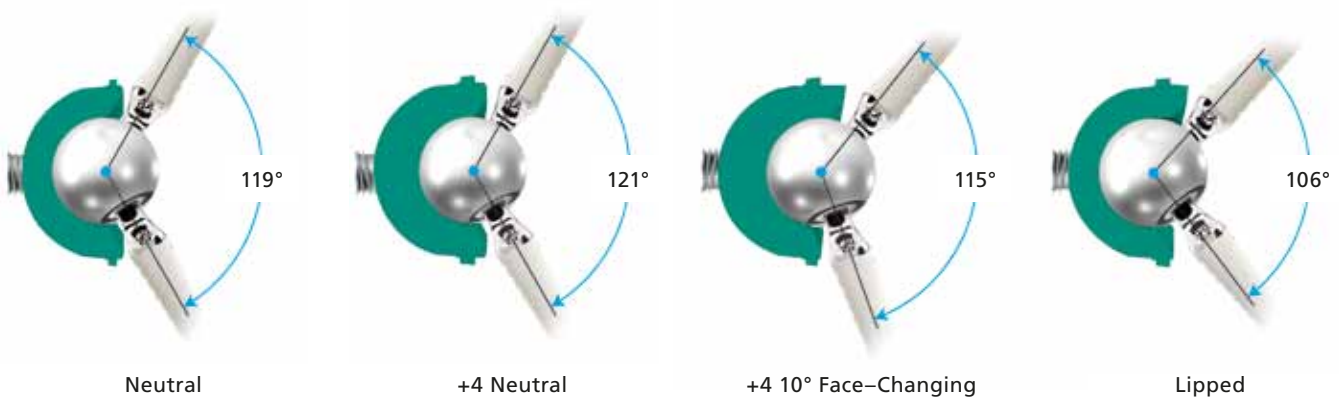

Figure 17
Liner alternatives – 28 mm Inner Diameter (ID) with DePuy AMT 12/14 Taper Stem (Range of Motion (ROM) calculated as AP sweep angle)¹¹

POLYETHYLENE LINER CONFIGURATIONS

The required ranges of angular movement between the acetabular and femoral components in a total hip joint replacement are specified in ISO 21535:2007(E).¹⁰

The ROM data presented in the below table derive from a computer analysis using 3-dimensional digital models of the actual components. The analysis was carried out on the combinations of PINNACLE and CORAIL[®] hip systems, including cups, liners, femoral heads and femoral components.⁹

The acetabular component model was oriented into an initial position which is considered a neutral position for a physiologically oriented acetabular cup component in terms of abduction and version. From the neutral position the femoral stem was rotated until the neck of the stem made contact with the rim of the acetabular cup.

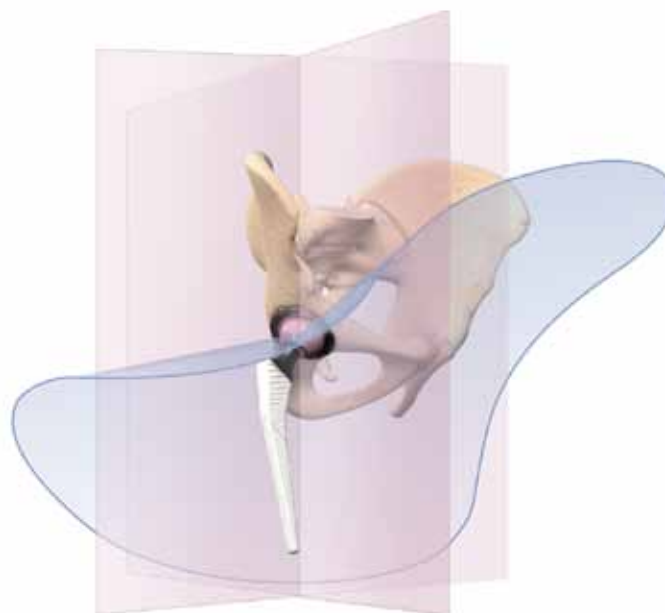

Figure 18

The range of motion (ROM) data of physiologically positioned acetabular and femoral components differs from commonly discussed sweep angles and describes maximum achievable movement in flexion and extension, and abduction and adduction (Figure 18). However, these are theoretical numbers and clinical results may be reduced due to skeletal impingement or the presence of soft tissues.

The angles achieved in each direction about each axis are shown in the following table:

Insert		Neutral		+4 Neutral		+4 10° Face		Lipped	
		Flexion / Extension	Abduction / Adduction	Flexion / Extension	Abduction / Adduction	Flexion / Extension	Abduction / Adduction	Flexion / Extension	Abduction / Adduction
PE	28 mm	166°	119°	167°	121°	165°	115°	143°	105°
PE	32 mm	177°	127°	177°	127°	172°	121°	151°	113°
PE	36 mm	177°	127°	180°	128°	174°	122°	N/A	N/A
PE	40 mm*	N/A	N/A	177°	127°	173°	121°	N/A	N/A
PE	44 mm*	N/A	N/A	174°	126°	170°	120°	N/A	N/A
PE	48 mm*	N/A	N/A	171°	124°	165°	112°	N/A	N/A
CERAMIC	28 mm	171°	123°	N/A	N/A	N/A	N/A	N/A	N/A
CERAMIC	32 mm	187°	133°	N/A	N/A	N/A	N/A	N/A	N/A
CERAMIC	36 mm	196°	139°	N/A	N/A	N/A	N/A	N/A	N/A

Table 1

Range of Motion (ROM) tested with a CORAIL 12/14 Taper Stem in accordance with ISO 21535:2009 standard for a physiologically positioned cup and stem. *MARATHON™ liners in sizes 40, 44 and 48 mm ID are part of the ES3™ system and are manufactured with a Charnley bore (raised lip).

IMPLANTING THE ACETABULAR CUP WITH SCREW FIXATION

Screw Insertion

The PINNACLE Sector Cup has three screw holes and is designed for insertion with screws. QUICKSET Acetabular Screw Instruments are recommended for screw insertion. Two medial hole alternatives are placed to enable screw placement up the posterior column in either the right or left hip. The single lateral screw provides additional access to the ilium.

The drill bit is controlled by the drill guide as it passes through selected holes into the acetabulum (Figure 19). The screw angle may vary by as much as 34° (Figure 20).¹¹ Drill bits of varying lengths are available. By seating the drill bit completely into the guide, holes corresponding to the effective length of the drill bit will be created.

Select holes where the prosthesis is to be anchored with cancellous screws so that the screws lie within a safe quadrant. The safe quadrant is defined by two lines from the anterior–inferior iliac spine through the centre of the acetabulum and posterior by a line from the sciatic notch to the centre of the acetabulum (Figure 21).



Figure 19
Drill Guide



Figure 20
Screw Angulation



Figure 21
Screw hole selection

IMPLANTING THE ACETABULAR CUP WITH SCREW FIXATION

Verify hole depth using the QUICKSET Depth Gauge. Alternating colours on the depth gauge represent 10 mm increments (Figure 22).

Insert 6.5 mm PINNACLE Hip Solutions Cancellous Bone Screws using a hex head screwdriver (Figures 23 and 24).

The 6.5 mm self-tapping screws have four-point cutting flutes with a blunt tip to reduce the risk of neurovascular injury (Figure 25).

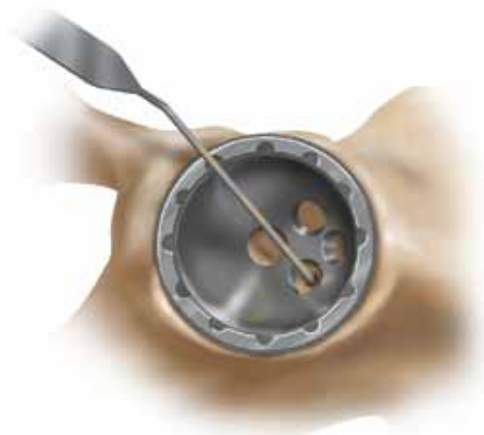

Figure 22 Depth Gauge



Figure 23 Screw insertion



Figure 24 Screw insertion

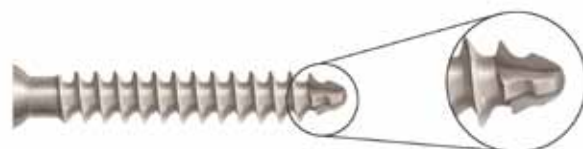

Figure 25 Screw tip

IMPLANTING THE ACETABULAR CUP WITH SPIKES

PINNACLE 300 Series Cup Insertion

Spikes placed along the radius of the PINNACLE 300 Series cup are coated and are for additional fixation (Figures 26 and 27). The spike height in the 300 Series cup ensures that the spike contacts bone on insertion at the same point that the cup contacts the rim of the prepared acetabulum. This gives the surgeon greater control when inserting the 300 Series cup and ensures the cup bottoms out in the dome of the acetabulum.

The recommended acetabular reaming technique for the PINNACLE 300 Acetabular Cup is either 1 mm under or line-to-line dependent on bone quality. It is important that the cup is well centred in the prepared acetabular cavity in the predetermined alignment indicated by the trial before being impacted.



Figure 26

Prior to cup impaction, spikes and rim engage simultaneously when the cup is centred and aligned



Spike orientation



Spike length

Figure 27

POLYETHYLENE LINER INSERTION AND IMPACTION

Following insertion of the final acetabular cup and femoral component, the trial liners can be used in the cup to confirm liner selection and evaluate joint stability and range of motion. Prior to inserting the final acetabular liner, thoroughly irrigate and clean the cup. **It is important to check the cup/liner locking groove to ensure it is clear of any debris.** Remove all soft tissue from the face of the cup so as not to impede liner seating (Figure 28). An apex hole plug may be used prior to liner insertion.



Figure 28
Liner placement

POLYETHYLENE LINER INSERTION AND IMPACTION

Prior to insertion/impaction, mate the liner anti-rotational device (ARD) tabs with the ARD scallops on the cup (Figure 29). There are six ARD tabs on the liners and 12 ARD scallops for cup diameters 48 mm – 72 mm. Also, there are four ARD tabs and eight ARD scallops in cup diameters 38 mm – 46 mm. This allows the liner to be rotated in 30° increments for cups 48 mm – 80 mm and 45° increments for 38 mm – 46 mm.

Seat the liner using the ID impactor that corresponds to the selected implant. Because the locking mechanism is tapered, it is important to impact the liner directly into the cup with multiple medium blows (Figure 30).

Impacting the liner in a tilted position may prevent complete seating. **Seating of the liner is visually confirmed when the liner ARDs are flush with the face of the acetabular cup;** however, the liner face will remain proud in relation to the cup face by approximately 1 mm for a neutral liner to 4 mm for a lateralised liner (Figure 31).



Figure 29
Align the liner anti-rotation tabs with cup scallops

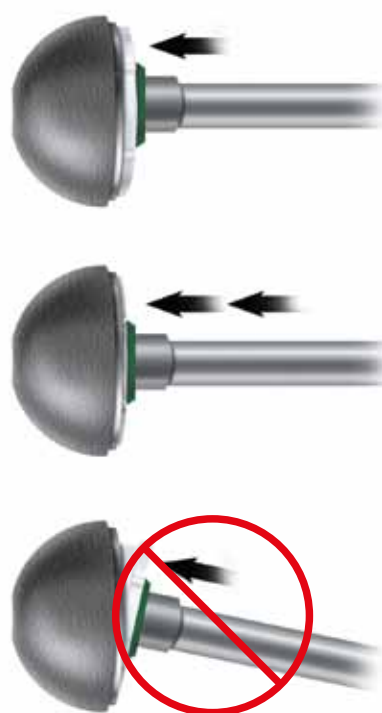

Figure 30
Liner impaction

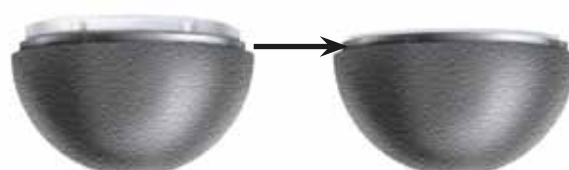

Figure 31
Seating height of a neutral liner

POLYETHYLENE LINER EXTRACTION

A polyethylene liner extractor is available to aid in polyethylene liner extraction and to help ensure the PINNACLE Acetabular Cup is not damaged during polyethylene liner extraction (Figure 32).

Open the extractor jaws and extend the ARD pin from the extractor tip. Place the ARD pin into an empty ARD and tightly close the jaws of the extractor (Figure 33). The teeth of the extractor should dig into the inner diameter of the polyethylene.

Once the ARD tip and teeth are secure on the polyethylene, advance the extraction knob clockwise until the polyethylene is removed (Figures 34 and 35).

It is important to note that an extracted polyethylene liner must not be reused.



Figure 32
Polyethylene Liner Extractor



Figure 33
Extractor placement



Figure 34
Rotation of Extraction Knob

Figure 35
Polyethylene liner removal

ALTERNATIVE BEARING LINER

Alternative Bearing Insertion Technique

To ensure optimal component placement when using alternative bearing (AB) liners, trialling is critical. Dedicated trials for liners help ensure the correct restoration of biomechanics.

If correct joint biomechanics, free of mechanical impingement, cannot be obtained with the alternative bearing trials, perform a trial reduction using the PINNACLE polyethylene liner trials. Then use the PINNACLE polyethylene liner that results in joint stability.

Before placing an alternative bearing into the PINNACLE cup, ensure all mating surfaces are clean and free of debris (Figure 36). Handle the alternative bearing liner carefully to avoid damage that could compromise the mechanical integrity of the liner taper locking mechanism.

Use of the PINNACLE Alternative Bearing (AB) Gripper (Figure 37) instrumentation is mandatory for the insertion of ceramic liners.

The surgical technique must be followed when inserting the ceramic liner into the acetabular cup to ensure correct alignment of the liner into the cup prior to impaction. Failure to do so could contribute to rim chipping during insertion or post-operative fracture.



Figure 36

Ensure all taper mating surfaces are clean and free of debris



Figure 37

Alternative Bearing Gripper

ALTERNATIVE BEARING GRIPPER

Alternative Bearing Insertion Technique

Assemble the appropriate size gripper to the inserter shaft aligning the slot of the gripper with the pin of the shaft (Figure 38).

Thread the appropriate size tip to the shaft (Figure 39). Make sure that the gripper is positioned such that it is touching the tip once it has been fully threaded (Figure 40).



Figure 38



Figure 39



Figure 40

ALTERNATIVE BEARING GRIPPER

Alternative Bearing Insertion Technique

Press-fit the liner on the gripper component. Verify that the liner is fully seated to ensure proper alignment (Figure 41).

Cautiously advance the liner into the incision and align the face of the gripper to the face of the cup.

Proper alignment is achieved when the instrument will no longer rotate due to the locking features between the gripper, cup and liner (Figures 42 and 43).



Figure 41



Figure 42



Figure 43

ALTERNATIVE BEARING GRIPPER

Alternative Bearing Insertion Technique

Press firmly on handle to introduce the liner into the cup (Figure 44). Do not attempt to fully engage the taper locking mechanism by striking the end of the AB Gripper Inserter.

Carefully remove instrument by pulling back the plastic gripper flange whilst pushing down gently on the gripper handle (Figure 45).

Palpate the liner to confirm proper taper alignment and seating in the cup (Figure 46).



Figure 44



Figure 45



Figure 46

ALTERNATIVE BEARING GRIPPER

Alternative Bearing Insertion Technique

Use an impactor with appropriate impactor tip for final seating of the liner (Figure 47). Final seating requires two to four moderate blows (Figure 48).

The nature of hard-on-hard bearings requires precise placement of femoral and acetabular components. It is important to optimise component placement to avoid mechanical impingement. To ensure optimal component placement when using alternative bearings, trialling is critical. Dedicated trials for alternative bearings help ensure the correct representation of biomechanics.

Note: if any other bearing surface has been impacted into the cup, a CERAMAX™ liner cannot be used. CERAMAX liners should only be used in new PINNACLE acetabular cups with an "as manufactured" taper.



Figure 47



Figure 48

ALTERNATIVE BEARING LINER

Alternative Bearing Extraction Technique

If it is necessary to remove an AB liner from a PINNACLE cup, thread the extractor handle onto the appropriate size AB extractor (Figure 49). Each cup size has a specific extractor, e.g., 48 mm cup uses a 48 mm extractor.

Note: AB extractors are available for cups starting at 44 mm OD up to 66 mm OD.

The AB extractor can be used with 28,32,36,40 and 44 mm ID

Place the three tips of the AB extractor into any three scallops on the face of the PINNACLE cup (Figure 50).

Push down the attached lever with thumb pressure to engage the suction cup against the inner face of the AB liner (Figure 51).

To remove the AB liner from the cup, impact the extraction handle lightly one to two times with a metal mallet. The resulting vibration will release the taper lock between the AB liner and the PINNACLE cup. The liner is then lifted out of the cup by the suction cup mechanism (Figure 52).



Figure 49
Alternative Bearing Extractor



Figure 50
Placement of Alternative Bearing Extractor



Figure 51
Engage the suction cup by pushing down on the lever



Figure 52
Impact the extractor handle lightly and lift the liner

FUNCTIONAL ASSESSMENT

Correct component placement is critical for the longevity of the hip reconstruction. Component placement is especially critical when alternative bearings are used in the reconstruction. The following illustration depicts the position of the femoral component neck with relation to the opening of the acetabular component with the reconstructed hip in neutral rotation (Figure 53).

To assess the combined anteversion of the femoral stem and acetabular component, place the patient in the lateral decubitus position with the operative hip gently flexed and internally rotated (Figure 54) until the circumference of the femoral head becomes coplanar with the opening of the acetabular insert (i.e., the axis of the femoral neck is perpendicular to the insert face). This position is depicted through a frontal view (Figure 55) and through a lateral view (Figure 56).

The angle between horizontal and the internally rotated operative leg provides an estimate of combined anteversion of the acetabular component and the femoral stem. Combined anteversion at 30-40 degrees is generally acceptable.



Figure 53

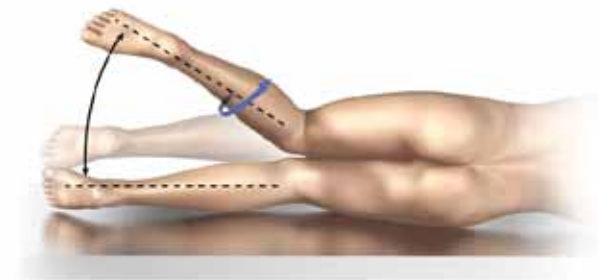

Figure 54
Combined Anteversion



Figure 55

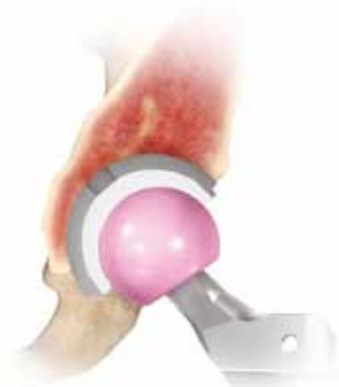

Figure 56

TIGHT EXPOSURE AND STABILITY TIPS

Tight Exposure

If the exposure is tight, completely incise the anterior capsule, perform a partial or complete release of the gluteus maximus tendon and release the reflected head of the rectus femoris.

Stability Assessment

Posterior Instability

With the trial implants in place, place the hip in 90 degrees of flexion, neutral abduction and internally rotate until subluxation. If there is less than 60 degrees of internal rotation, determine the cause of instability.

Prosthetic Impingement	
Problem	Femoral implant neck levers on the component rim.
Solution	Reposition cup to correct version/abduction.
	Increase head size and evaluate.
	Increase anteversion of the stem.

Bony Impingement	
Problem	Prosthetic neck levers on anterior acetabular osteophyte.
	Greater trochanter impinging on ilium.
Solution	Remove anterior osteophytes from the acetabulum.
	Increase stem offset to move the trochanter away from the ilium.
	Remove anterior trochanteric bone.

Soft Tissue Impingement	
Problem	Redundant anterior capsule causes head to lever out of socket.
Solution	Resect redundant anterior capsule.

Soft Tissue Laxity	
Problem	Lax soft tissue leading to multidirectional instability.
Solution	Increase the neck length.
	Advance the trochanter.

Stability Assessment

Anterior Instability

With the implant trial in place, place the hip in extension and maximally externally rotate; subluxation should not occur. If subluxation occurs, determine the cause of instability.

The Keys to Managing Stability Are:

1. Ensure the appropriate anteversion/abduction of the acetabular and femoral components.
2. Restore correct leg length and femoral offset.
3. Repair the posterior capsule and rotators.
4. Work with the patient to ensure appropriate post-operative precautions are followed.

Prosthetic Impingement	
Problem	Prosthetic neck impinges on the acetabular cup.
Solution	Reposition acetabular component to decrease anteversion.
	Decrease anteversion of the femoral stem.
	Increase the head size and re-evaluate.

Bony Impingement	
Problem	Femur impinges on the ischium.
Solution	Increase femoral offset.
	Decrease acetabular or stem anteversion.

CLOSURE

Closure is based on the surgeon's preference and the individual case. If the capsule is retained it is closed separately. The gluteus minimus and gluteus medius can be closed separately or as a single unit.

At least one stitch is passed through bone. Tension is relieved during the repair with slight internal rotation.

The repair should be tested throughout the hip range of motion.



ORDERING INFORMATION

Instruments

2015-24-000	PINNACLE Poly Impactor Handle	2218-90-003	AB Curved Handle Assembly
2217-00-002	PINNACLE Primary Template	2218-90-004	PINNACLE 40 mm TIP
2217-00-020	PINNACLE Alternative Bearing Suction Cup Inserter	2218-90-005	PINNACLE 44 mm TIP
2217-00-044	PINNACLE Alternative Bearing Extractor Body 44	2218-90-007	PINNACLE 32 mm TIP
2217-00-046	PINNACLE Alternative Bearing Extractor Body 46	2218-90-044	PINNACLE 44 mm Gripper
2217-00-048	PINNACLE Alternative Bearing Extractor Body 48	2218-90-046	PINNACLE 46 mm Gripper
2217-00-050	PINNACLE Alternative Bearing Extractor Body 50	2218-90-048	PINNACLE 48 mm Gripper
2217-00-052	PINNACLE Alternative Bearing Extractor Body 52	2218-90-050	PINNACLE 50 mm Gripper
2217-00-054	PINNACLE Alternative Bearing Extractor Body 54	2218-90-052	PINNACLE 52 mm Gripper
2217-00-056	PINNACLE Alternative Bearing Extractor Body 56	2218-90-054	PINNACLE 54 mm Gripper
2217-00-058	PINNACLE Alternative Bearing Extractor Body 58	2218-90-056	PINNACLE 56 mm Gripper
2217-00-060	PINNACLE Alternative Bearing Extractor Body 60	2218-90-058	PINNACLE 58 mm Gripper
2217-00-062	PINNACLE Alternative Bearing Extractor Body 62	2218-90-060	PINNACLE 60 mm Gripper
2217-00-064	PINNACLE Alternative Bearing Extractor Body 64	2218-90-062	PINNACLE 62 mm Gripper
2217-00-066	PINNACLE Alternative Bearing Extractor Body 66	2218-90-064	PINNACLE 64 mm Gripper
2217-50-001	PINNACLE Polyethylene Liner Extractor	2218-90-066	PINNACLE 66 mm Gripper
2217-50-004	Impactor Tip 22.225 mm	2244-10-000	Acetabular Alignment Guide
2217-50-005	Impactor Tip 26 mm	2244-14-000	Poly Extractor Screwdriver
2217-50-006	Impactor Tip 28 mm	2274-02-000	QUICKSET Ratchet Screwdriver Handle
2217-50-007	Impactor Tip 32 mm	2274-47-000	QUICKSET Tapered Rigid Hex Screwdriver
2217-50-008	Impactor Tip 36 mm	2274-48-000	QUICKSET Tapered Flexible Hex Screwdriver
2217-50-041	PINNACLE Straight Cup Impactor	2274-49-000	QUICKSET Tapered Hex Screwdriver Cardan
2217-50-044	PINNACLE Version Guide	2274-50-000	QUICKSET Cross Head Screwdriver
2217-50-048	PINNACLE Bantam Acetabular Cup Impacter Adapter	2274-52-000	QUICKSET Flexible Quick Couple Drill Shaft
2217-50-050	PINNACLE Trial Liner Base	2274-53-000	QUICKSET Rigid Quick Couple Drill Shaft
2217-50-051	PINNACLE Trial Liner Lid	2274-54-500	QUICKSET Drill Guide 3.8 mm
2217-50-053	PINNACLE Alternative Bearing Extractor Case Complete (Case, Tray, Lid)	2274-55-000	QUICKSET Screw Holding Forceps
2217-50-060	PINNACLE Impactor Tip 40 mm	2274-56-000	QUICKSET Ø 3.8 mm Drill Bit 25 mm
2217-50-061	PINNACLE Impactor Tip 44 mm	2274-58-000	QUICKSET Ø 3.8 mm Drill Bit 55 mm
2217-50-062	PINNACLE Impactor Tip 48 mm	2274-59-000	QUICKSET Ø 3.8 mm Drill Bit 70 mm
2217-60-015	Primary Case Complete (Case, Tray, Lid)	2274-60-000	QUICKSET 70 mm Depth Gauge
2217-60-020	PINNACLE AB Inserter Case	2274-63-000	QUICKSET Tapered Hex Screwdriver U-Joint
2218-90-001	PINNACLE 28 mm TIP	2346-01-000	Apex Hole Elim Tapered Hex Driver
2218-90-002	PINNACLE 36 mm TIP	9599-10-000	Replacement Suction Cup

For more detailed information on PINNACLE implants and related trial instruments please refer to the PINNACLE Primary System Overview

References

1. Learmonth ID, Young C, Rorabeck C. The operation of the century: total hip replacement. *Lancet* 2007;370:1508-19.
2. Archbold HAP et al. The transverse acetabular ligament: an aid to orientation of the acetabular component during primary total hip replacement. *J Bone Joint Surg.* 2006;88B:883-6.
3. Udomkiat P, Dorr LD, Wan Z. Cementless hemispheric porous-coated sockets implanted with press-fit technique without screws: average ten-year follow-up. *J Bone Joint Surg.* 2002;84A:1195-200.
4. Schmalzried TP, Guttman D, Grecula M, Amstutz H. The relationship between the design, position, and articular wear of acetabular components inserted without cement and the development of pelvic osteolysis. *J Bone Joint Surg.* 1994;76A:677-688.
5. Kennedy JG, Rogers WB, Soffee KE, et al. Effect of acetabular component orientation on recurrent dislocation, pelvic osteolysis, polyethylene wear and component migration. *J Arthroplasty* 1998;13:530-534.
6. Prudhommeaux F, Hamadouche M, Nevelos J, et al. Wear of alumina-on-alumina total hip arthroplasty at a mean 11-year followup. *Clin Orthop Relat Res.* 2000; 397:113.
7. Walter WL, O'Toole GC, Walter WK, Ellis A, Zicat BA. Squeaking in ceramic-on-ceramic hips: the importance of acetabular component orientation. *J Arthroplasty.* 2007;22:496-503.
8. Tower SS, Currier JH, Currier BH, Lyford KA, Van Citters DW, Mayor MB. Rim cracking of the cross-linked longevity polyethylene acetabular liner after total hip arthroplasty. *J Bone Joint Surg.* 2007;89A(10):2212-7.
9. Data on file – DVE-001038-ROM December 2008.
10. International Standards Organisation, ISO 21535:2009 Non-active surgical implants. Joint replacement implants. Specific requirements for hip-joint replacement implants. Available from URL: <http://www.iso.org> [Accessed 17/12/12].
11. Data on File. DePuy Synthes Internal Test report L00000924 8/2013.



DePuy Orthopaedics EMEA is a trading division of DePuy International Limited.
Registered Office: St. Anthony's Road, Leeds LS11 8DT, England
Registered in England No. 3319712

DePuy Orthopaedics, Inc. 700 Orthopaedic Drive Warsaw, IN 46581 USA Tel: +1 (800) 366 8143 Fax: +1 (574) 267 7196	DePuy International Ltd St Anthony's Road Leeds LS11 8DT England Tel: +44 (0)113 387 7800 Fax: +44 (0)113 387 7890
---	--



©DePuy International Ltd. and DePuy Orthopaedics, Inc. 2014.
All rights reserved.

depuysynthes.com

CA#DPEM/ORT/1112/0366(1) Issued: 02/14